

NOSE ASSEMBLY DATA SHEET

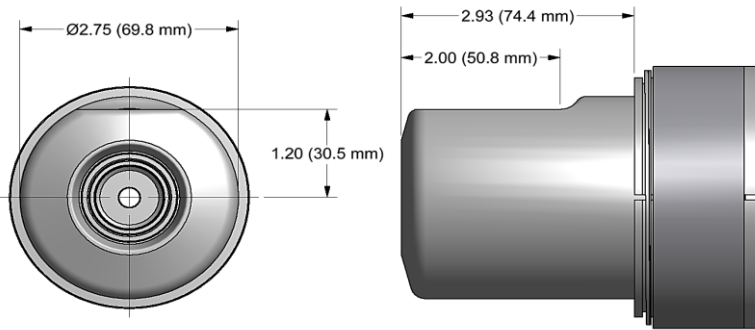

1. Ensure Piston is in full forward position.
2. Disconnect tool control cord.
3. Screw assembled Collet onto Piston until top of collet flat lines up with face of tool (see below).
4. If Collet Lock (9) is not in Piston groove, continue to turn 1/4 turn clockwise, or less, until lock engages groove.
5. Tighten Set Screw (10).
6. Slide Anvil (1) over assembled Collet. Install Split Ring, Sleeve and Retaining Ring (furnished with tool) .

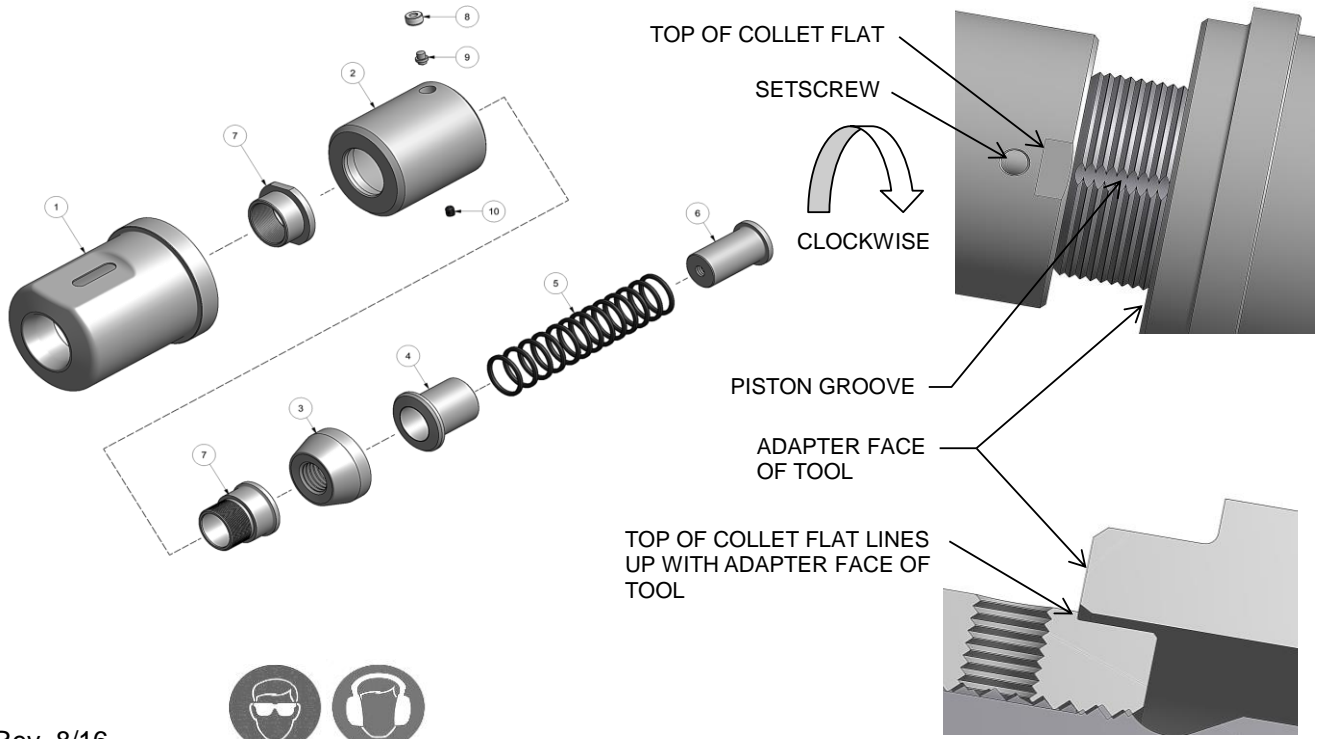

Rev. 8/16

GAGE BILT
MADE in USA

44766 Centre Court Clinton Twp. MI 48038 USA
Ph: +1 (586) 226-1500 Fax: +1 (586) 226-1505
solutions@gagebilt.com / www.gagebilt.com

Type:	Fasteners:	Recommended Tool: GB2630
Self-Releasing	Lockbolt 7/8" Diameter	

Ref. No.	Qty.	Description	28-2630-28
1	1	Anvil	12801
2	1	Collet Assembly (Inc. ref. # 2,7,8,9 & 10)	22800
3	1	Jaw Set	32801
4	1	Follower	42802
5	13	O'ring	400815
6	1	Sleeve	62801
7	1	Release & Ejector	82800
8	1	Retainer - Collet	54505
9	1	Pin - Collet Lock	54503
10	1	Set Screw	A-280