

NOSE ASSEMBLY DATA SHEET

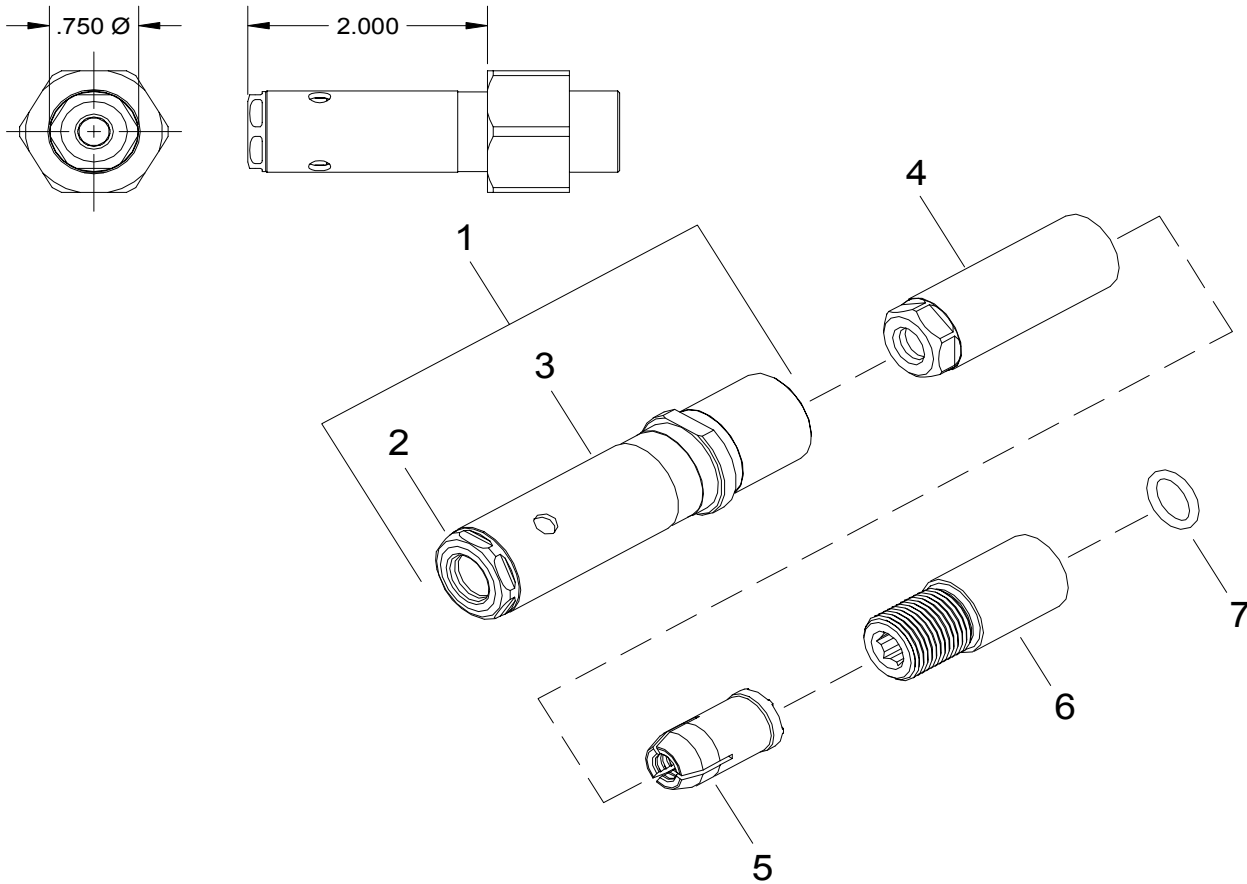

1. Drop jaws #5 into collet #4.
2. Snug extension #6 and collet #4 together using 9/16" wrench and 1/4" hex key in rear of extension #6.
3. Place o'ring #7 in rear of extension #6.
4. Thread assembly onto piston and snug with 9/16" wrench on collet #4 and hex key (provided with tool) into rear of piston.
5. Slide anvil #1 over assembled collet #4 and extension #6.
6. Slide nut from tool (retaining nut stop not used on this nose assembly) over anvil #1 and tighten.



5/07 Rev. 3/11

GAGE BILT
MADE IN U.S.A.

GAGE BILT Inc.

44766 Centre Court (586) 226-1500
Clinton Twp. MI 48038 (586) 226-1505 Fax
e-mail:solutions@gagebilt.com / www.gagebilt.com

Type:		Fasteners:	Recommended Tool: GB722	
Non Self-Releasing 3/16 & 1/4 Ø		MAGNA-GRIP® Maxlok®	Alternate Tools: GB731 & GB2480	
Ref. No.	Qty.	Description	MG06-722-20	MG08-722-20
1	1	Anvil & Holder Assembly	16683	18871
2	1	Anvil	16634	18872
3	1	Holder	12242-1	12242-4
4	1	Collet	20636	20841
5	1	Super-Grip Jaw Assembly	30652-S	30860-S
6	1	Extension	70823	70823
7	1	O'Ring	400778	400778